

VC15-110

Service Information

(2004 > 2008)

Laney
POWER TO THE MUSIC
www.laney.co.uk

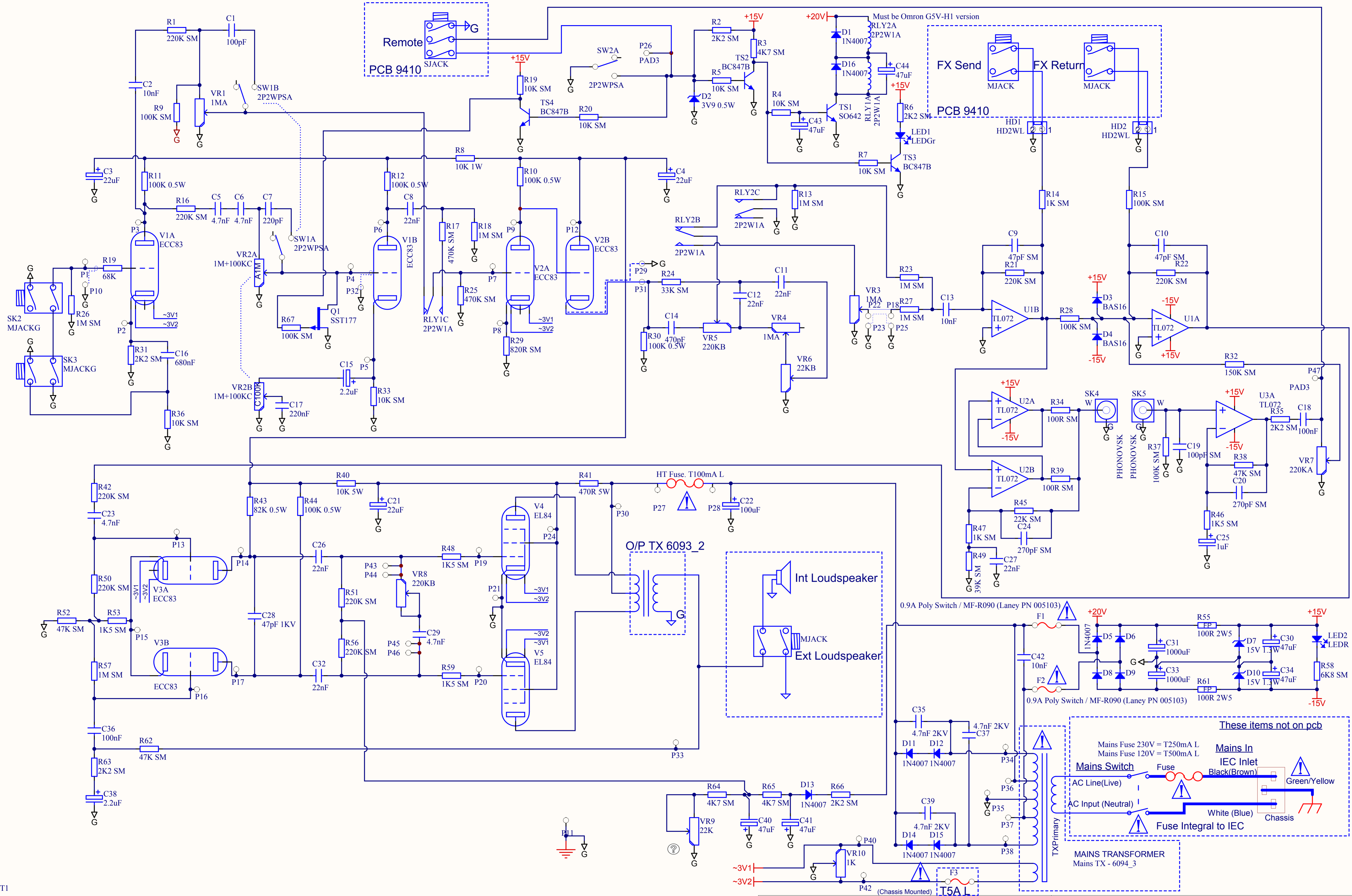

BRKT1
BRKT2

Issue 5.
R4 from 10K to 4K7
Relay spec > G5V-2-H1
Add R9
Delete R54, R60
Add F1, F2

Issue 6.
Added C44 47u cap across RLY1
coil.
Change R45 from 10k to 22k to
increase reverb level.

Tubes Chassis mounted and hardwired to PCB.
R19 routed to tube base, not on pcb

Flame proof resistor
Must only be replaced with same type and rating

Indicates safety critical component
Must only be replaced with approved type

Title: VC15 Preamp PCB		
Size: A3	Number: 9416	Revision: 6
Date: 04/02/2008	Time: 15:41:21	Sheet 1 of 1
Original File: 9416_6.Sch		

Steelpark Road
Coomb's Wood
Industrial Estate West
Halesowen
UK
www.laney.co.uk

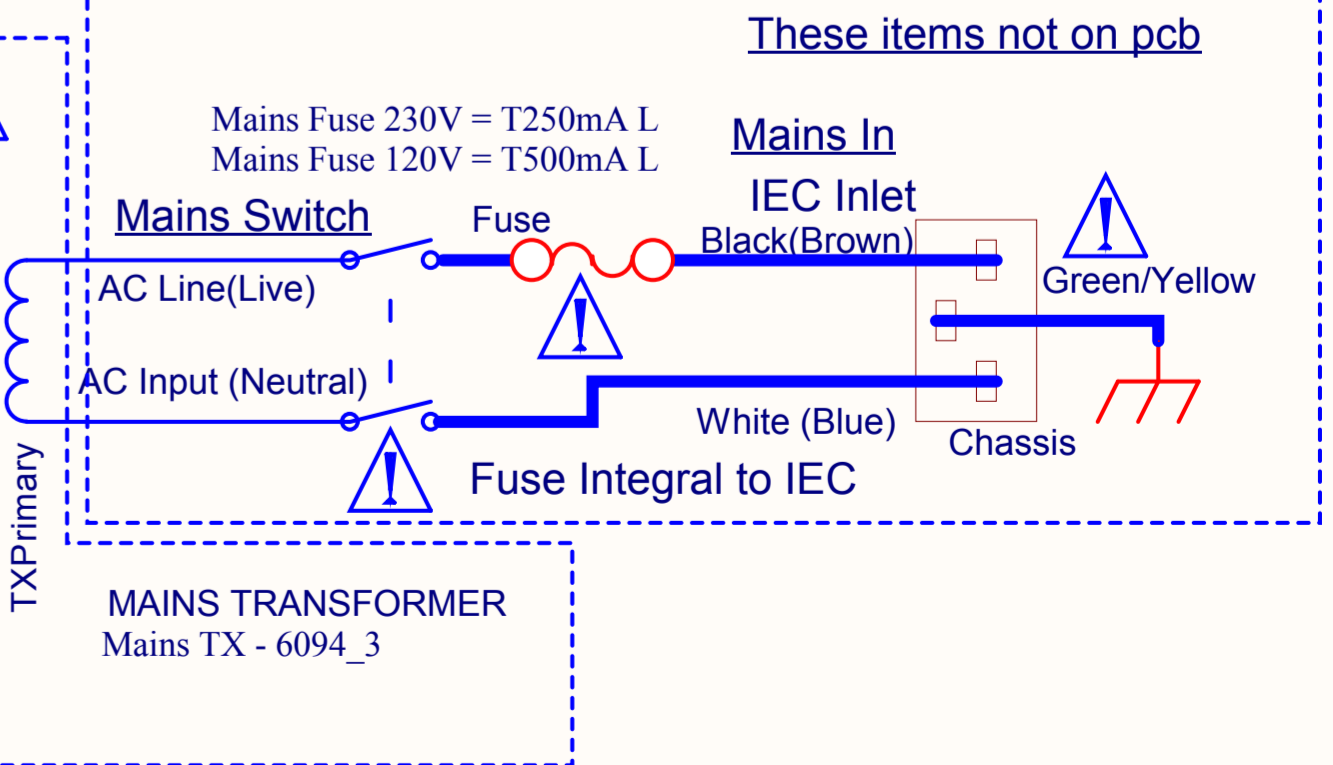

VC15-110 SPARE PARTS LIST

Laney

Model No. VC15-110

SPARES ITEM	DESCRIPTION	PART No.
-------------	-------------	----------

Mains Transformer	100V	LC15 100V Mains Transformer	006150	
	115V	LC15 115/230V Mains Transformer	006094	
	230V	LC15 115/230V Mains Transformer	006094	
Output Transformer		Output TX 15W	006093	
Reverb Unit		3 Spring Reverb Unit	10006	
Switch	Power	5A DPDT Rocker Switch	530027	
Mains Fuse	230V	T250mA Spiral wound 20mm	005528	
	115V	T500mA Spiral wound 20mm	005566	
Corner	Front	Stainless Steel	10049	
	Back	Stainless Steel	10048	
Jack Sockets		1/4 Jack Socket - Mono - Gold	005096	
		1/4 Jack Socket PCB Mount	005002	
PCB Complete	9416	Pre-Amp PCB Complete	60052	
	Pots	VR1/3/4	1M Log 6mm Spline	004070
		VR5/8	220K Lin 6mm Spline	004065
		VR7	220K Log 6mm Spline	004078
		VR6	22K Lin 6mm Spline	004061
		VR2	Split 1M / 100K Antilog Dual 6mm Spline (100KC on front / A1M on back)	004116
	9410	Fx send/return PCB Complete	60048	
Badge		140mm Laney Badge	10057	
Fascia Panel		VC15-110 Fascia	8M-9272	
Control Knob		20mm Chicken Head	005631	
Handle		Leather Strap Handle	10101	
Loudspeaker		10" Jensen C10Q8	51901	
Loudspeaker Jack Lead		Chrome Jack > 4.8mm Terminals	010112	
Mains Inlet Socket		IEC Fused	005005	
HT Fuse Carrier		HT Fuse Carrier	005502	
HT Fuse		T100mA Spiral wound 20mm	005586	
Tubes	1	EL84 Matched Set	005562	
	2	ECC83 Hi-Grade	005570	
	3	ECC83 STD	005548	
Tube Base		Ceramic Base socket B9A	005577	
Mains Lead		Country Dependant		
Foot Switch		Foot Switch	FS2	
Foot Switch Jack Socket		Stereo Jack Socket PCB Mount	005003	
Phono sockets		Phono Socket Single Skeleton	005081	
Feet		Screw-on Rubber Feet	10059	
Cabinet Minus Loudspeaker		Carcase plus fittings - VC15-110	007037	
Capacitor		100UF 500V Electrolytic Capacitor	002032	
Manual		VC15-110 User Manual	007174	